

VZ-34CGM

UWQHD Curved SECURITY MONITOR



VZ-34CGM ADVANTAGES

- 34" Curved LED Panel
- Supports UWQHD (3440x1440) Resolution
- Ultrawide 1500R Curved Screen
- High Response Time - 1ms / Refresh Rate - 165hz
- Support MPRT / Support PIP/PBP
- Supported Display Port (1.2) In x2, HDMI (2.0) In x2, Audio Out x1
- Supports HDR 10
- Tilt 15° ~ -5°, Swivel ± 30°, Height Adjustment 5.11" (130 mm)
- Wide Viewing Angle (IPS Panel)

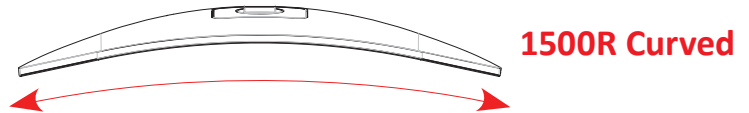

MODEL #	VZ-34CGM	
VIDEO		
Screen Size	34"	
Max. Resolution	3440 x 1440 @60Hz	
Pixel Pitch	0.23175 mm x 0.23175 mm	
Brightness	300cd/m ² (Typical)	
Contrast Ratio	3000:1	
Aspect Ratio	21 : 9	
Viewing Angle (H/V)	178° / 178°	
Display Color	16.7 M	
Response Time	< 1 ms	
INTERFACE		
Display Port In	2	
HDMI (2.0) In	2	
Audio Out	1	
AUDIO		
Built in speaker	3W x 2	
SPECIAL FEATURES		
DDC/CI (Command)	Support	
MPRT (Moving Picture Response Time)	Support	
Advanced DCR (Dynamic Contrast Ratio)	Support	
Adaptive Sync	Support	
Blue Light Filter	Support	
HDR	Support	
PIP & PBP	Support	

DIMENSIONS & WEIGHT		
Outline Dimension (W x H x D)	with Stand	31.96" x 20.29" x 9.2" 811.8 mm x 515.6 mm x 233.9 mm
	without Stand	31.96" x 14.39" x 4.58" 811.8 mm x 365.6 mm x 116.4 mm
		Net Weight / Gross Weight
MOUNT		
VESA	75 x 75 mm (M4)	
GENERAL		
Power	Electrical Ratings	DC 12V (AC100 ~ 240V (50/60Hz)) / 5A
	Consumption	≤ 60 W
Regulations	CE, FCC (A), RoHS	
Operating Temperature	32 - 122°F / 0°C ~ 50°C	
Operating Humidity	20 ~ 85% RH	
Language (OSD)	English	
Compatible Mounts	Wall	VZ-WM50, VZ-AM02-A
	Ceiling	VZ-CMKIT-01, VZ-CMKIT-02, VZ-CM308
Accessories	Stand (1set), Manual (1pc), Power Adapter (1pc), DP Cable (1pc)	

VZ-34CGM

UWQHD Curved SECURITY MONITOR

DIMENSIONS

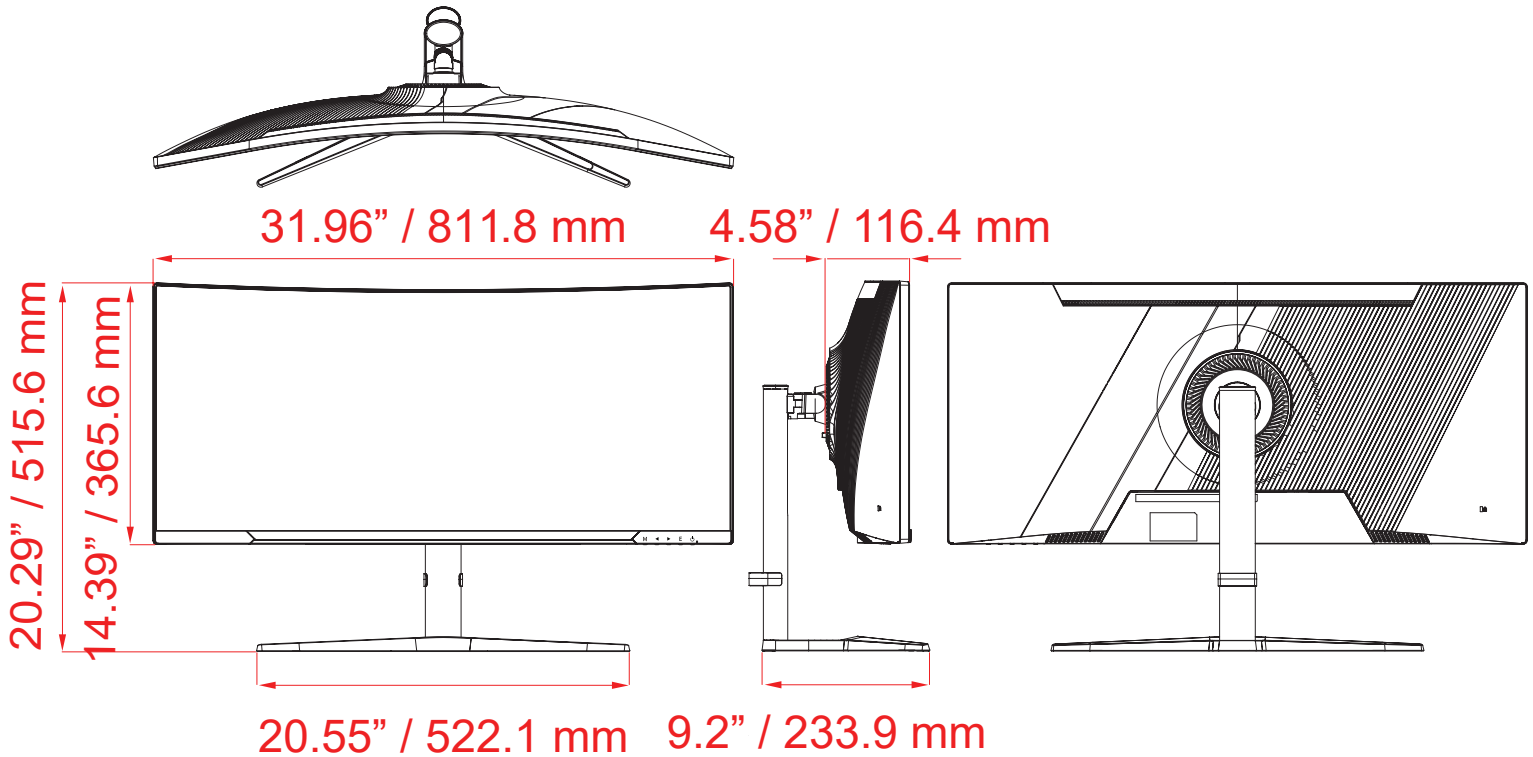

INTERFACE

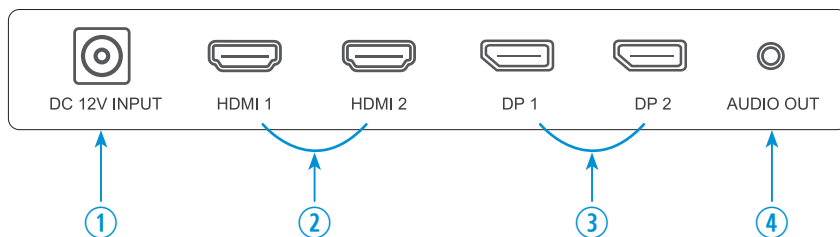

1. DC 12V
2. HDMI IN x2
3. Display Port IN x2
4. Audio OUT

Contact ViewZ

- Address : 1030 N ARMANDO ST., ANAHEIM, CA 92806
- Phone : (714) 996-1177, Fax : (714) 996-1138
- Sales : sales@viewzusa.com