



# SPA-P100B

## IP Pendant Speaker



### Key Features

- Amplifier: Built in 10W Class D
- Power: PoE(IEEE 802.3 af type 1 Class 3) , PoE+(IEEE 802.3 at type 2 Class 4)
- Internal memory: 1 GBytes
- Frequency Range (-10dB): 130Hz~20kHz
- Max. Sound Pressure Level : 101dB
- Sensitivity (1Watt): 91dB
- Supported Protocols: IPv4, HTTP, HTTPS, SIP, mDNS, DNS, NTP, TCP, UDP, DHCP, ARP, ICMP, SNMP(v3)
- TTS: English(US, UK), German, French, Spanish, Russian

# SPA-P100B

IP Pendant Speaker



## Specifications

Product	
IP Audio Type	IP Pendant Speaker
Amplifier	
Description	Built in 10W Class D
Network	
Ethernet	10/100 Base-T
Memory	
Internal Memory	1 GBytes
External Memory (Micr SD)	SDHC upto 32GB (SANDISK)
Contact	
Contact Input. Dry contact	One Channel
Contact Output. Dry contact (NO)	One channel
General	
Operating Temperature	-20°~+50°C(-4°F~+122°F)
Operating Humidity	10~85%RH(Non-Condensing)
IP Code	N/A
Weight	2.1Kg (4.63lb)
Size	ø269*256(H)mm
Color	Black
Certificate	EMC : KS C 9832/9835,EN 55.32/55035,FCC Part 15 Subpart B,ICES-003, Safety : UL 2043,UL 62368-1,CAN/CSA 62368-1
Power	
PoE	PoE (IEEE 802.3 af type 1 Class 3)
PoE+	(IEEE 802.3 at type 2 Class 4)
Embedded MIC	
Input Sensitivity	Sound Level Meter
Frequency Response	Sound Level Meter

## Audio

Supported Audio Format	WAV, MP3 in mono/stereo from 64 kbps to 320 kbps. Sampling rate from 16kHz up to 48 kHz
------------------------	---

## Speaker

Speaker Component	2 Way 8" LF Drive & 2" HF Driver. Passive type
Max. Sound Pressure Level (PoE)	97 dB
Max. Sound Pressure Level (PoE+)	101 dB
Frequency Range (-10 dB)	130Hz~20kHz
Sensitivity (1 Watt)	91 dB
Coverage Pattern	(HxV) : 130°(1kHz) / 60°(4kHz)

## Network Protocol

Security	Password protection : admin, setup, user, guest (sha-2, Digest authentication, User access log)
Supported Protocols	IPv4, HTTP, SIP, mDNS, DNS, NTP, TCP, UDP, DHCP, ARP, ICMP

## System Integration

Application Programming Interface	SUNAPI(HTTP API), ONVIF Profile S
VoIP	Tested with SIP clients such as Grandstream, Yealink, Cisco, MicroSIP softphone and PBX supplier such as Asterisk. Supported SIP features : DTMF (RFC2833), Supported codecs : PCMU, PCMA, speex/8000, speex/16000
TTS	English (US, UK), German, French, Spanish, Russian
Audio Monitoring	Speaker test by graphic level meter (Built in test tool)
Event & Preset	Virtual Contact, Dry contact
Functional Monitoring	Connection verification, Built-in system logging

SPA-P100B

# SPA-P100B

IP Pendant Speaker



CAD

Unit: mm [inch]

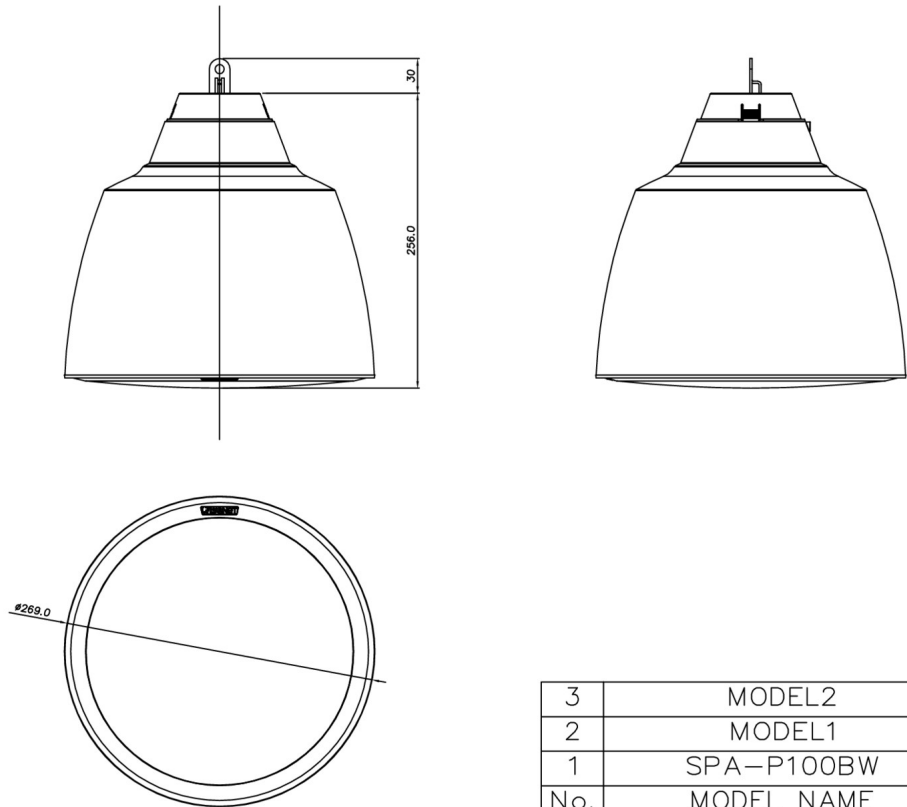

3	MODEL2	
2	MODEL1	
1	SPA-P100BW	23.05.10
No.	MODEL NAME	DATE
Unit: mm[inch] SCALE: 1/1		© Hanwha Techwin

© Hanwha Techwin Co., Ltd. All rights reserved.