



# SHP-1680FPW

## In-ceiling Mount



### Key Features

- Enclosure: Aluminum / Top cover : Polycarbonate (PC)
- Dimensions : Ø268mm x H209mm (10.55" x 8.23")
- Weight : 1,300g (2.87 lb)
- Color : White

# SHP-1680FPW

In-ceiling Mount



## Specifications

Mechanical	
Color	White
Material	PC(Polycarbonate), Aluminum
RAL code	RAL9003
Product dimensions / weight	ø268x209mm(ø10.55x8.23") / 1300g(2.87lb)
Tile thickness	3~70mm
Conduit hole	19.1mm(3/4")(M25), 12.7mm(1/2")(M20)
Supported products	QNP-6250, QNP-6320 ※ For further compatible models, please visit our website or use Toolbox

# SHP-1680FPW

In-ceiling Mount



## CAD

Unit: mm [inch]

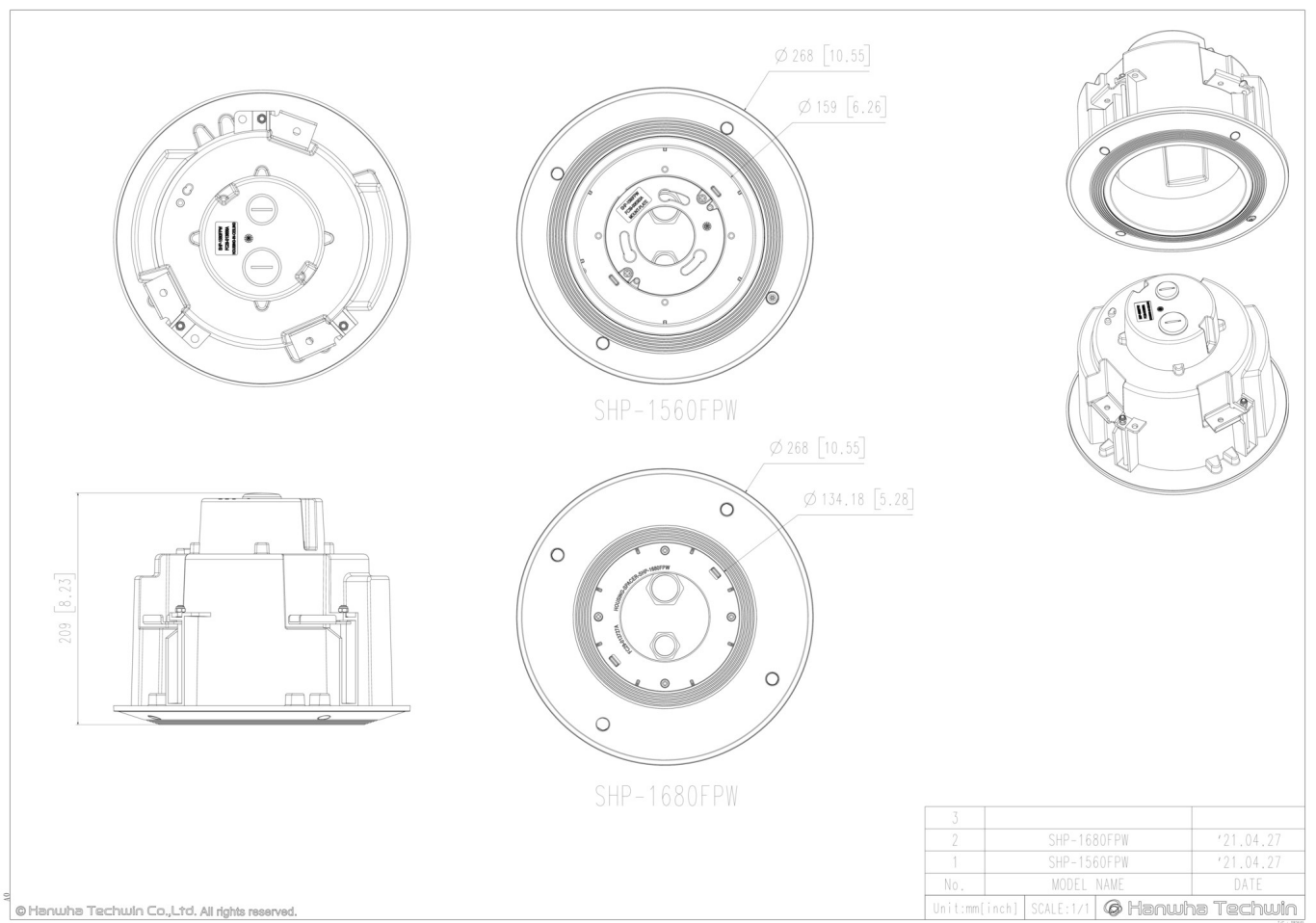

© Hanwha Techwin Co., Ltd. All rights reserved.