



SHD-1200FW

In-ceiling Mount



Key Features

- Color: White
- Material : PC(Polycarbonate)
- Dimensions : 175x162x147mm (6.89x6.38x5.79")
 - ※ Ceiling hole size : ø140mm (ø5.51")
- Weight : 275g (0.61lb)
- Max. load : 0.6kg (1.32lb)
 - ※ Maximum load of ceiling board : 3kg (6.61lb)

Compatible Devices



QNV-C8013R



QNV-C8023R

SHD-1200FW

SHD-1200FW

In-ceiling Mount



Specifications

Mechanical	
Color	White
Material	PC(Polycarbonate)
RAL code	RAL9003
Product dimensions / weight	175x162x147mm(6.89x6.38x5.79") / 275g(0.61lb)
Tile thickness	10~60mm(0.4~2.4")
Max. load	0.6kg(1.32lb) ※ Maximum load of ceiling board: 3kg(6.61lb)
Supported products	QNV-C8013R, QNV-C8023R ※ For further compatible models, please visit our website or use Toolbox

SHD-1200FW

In-ceiling Mount



CAD

Unit: mm [inch]

SHD-1200FW In-Ceiling Mount

Reference image

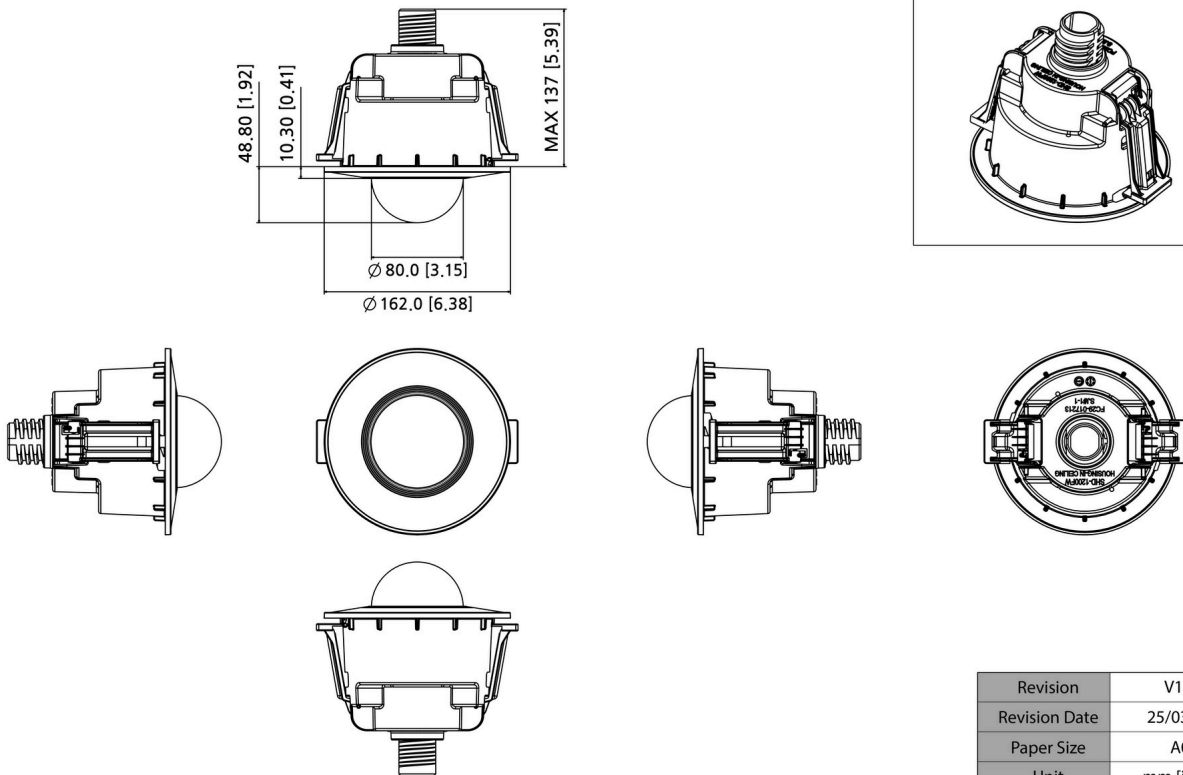
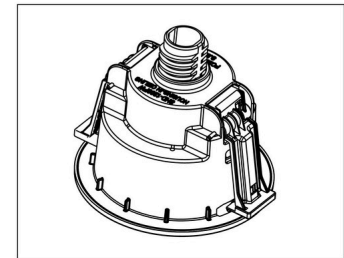

Revision	V1.0
Revision Date	25/03/07
Paper Size	A0
Unit	mm [inch]
Scale	1:1

©Hanwha Vision Co., Ltd. All right reserved.