



SHD-1100FPW

In-ceiling Mount



Key Features

- Color: White
- Material : Aluminum
- Product dimensions : $\phi 180 \times 100.7 \text{mm}$ ($\phi 7.09 \times 3.96 \text{''}$)
- Weight : 676.4g (1.49lb)
- Max. load : 1.5kg (3.31lb)
 - ※ Maximum load of ceiling board : 3kg (6.61lb)

Compatible Devices



QND-C8013R



QND-C8023R

SHD-1100FPW

In-ceiling Mount



Specifications

Mechanical	
Color	White
Material	PC(Polycarbonate), Aluminum
RAL code	RAL9003
Product dimensions / weight	ø180x100.7mm(ø7.09x3.96") / 676.4g(1.49lb)
Tile thickness	10~70mm(0.4~2.8")
Mount Screw size	TR20
Max. load	1.5kg(6.61lb) ※ Maximum load of ceiling board: 3kg(3.31lb)
Conduit hole	12.7mm(1/2")(M20), 19.1mm(3/4")(M25)
Supported products	QND-C8013R, QND-C8023R ※ For further compatible models, please visit our website or use Toolbox

SHD-1100FPW

SHD-1100FPW

In-ceiling Mount

CAD

Unit: mm [inch]

SHD-1100FPW In-ceiling Mount

Reference image

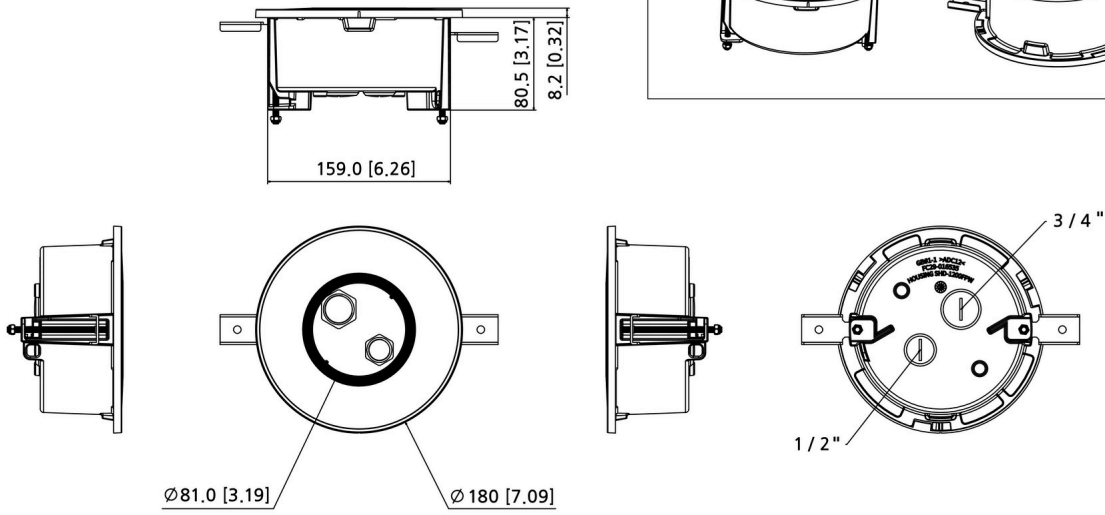
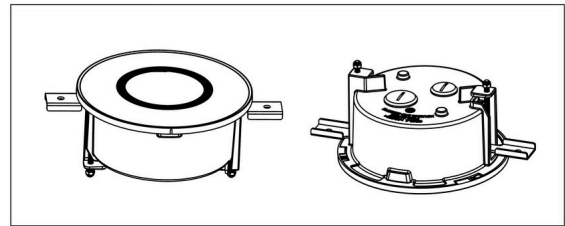

Revision	V1.0
Revision Date	25/04/04
Paper Size	A0
Unit	mm [inch]
Scale	1:1

©Hanwha Vision Co., Ltd. All right reserved.