

SBV-A14B

Back Box



Key Features

- Product dimensions / weight :
Ø144.0x51.0mm(Ø5.67x2.01"), 440g
- Mount Screw size : TR20
- Conduit hole : 19.1mm(3/4") (M25)

Compatible Devices



QNV-6072R



QNV-6072R1



QNV-6082R



QNV-6082R1



QNV-7082R



QNV-8080R



LNV-6072R



ANV-L6012R



ANV-L6082R



ANV-L7012R



ANV-L7082R



ANO-L6012R



ANO-L6022R



ANO-L6082R

SBV-A14B

Back Box



Specifications

Mechanical	
Color	White
Material	Aluminum
RAL code	RAL9003
Product dimensions / weight	ø144x51mm / 450g
Mount Screw size	TR20
Max. load	2kg
Conduit hole	19.1mm(3/4")(M25)
Supported products	ANO-L6082R, ANO-L7082R, ANV-L6082R, ANV-L7082R, ANE-L6012R, ANE-L7012R ※ For further compatible models, please visit our website or use Toolbox

SBV-A14B

Back Box



CAD

Unit: mm [inch]

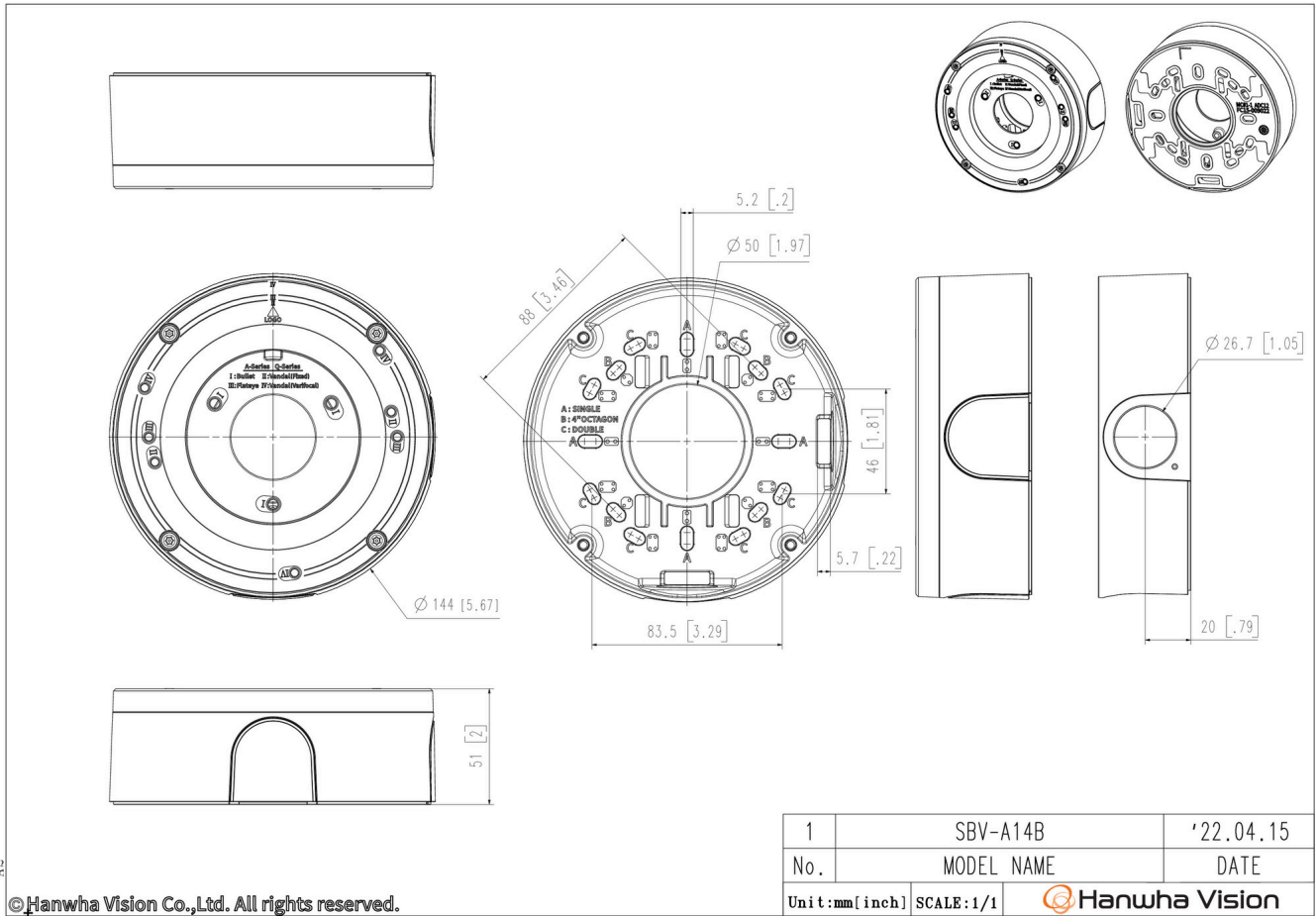

A2

© Hanwha Vision Co., Ltd. All rights reserved.