

SBP-150PMW

Pole Mount



Key Features

- Color : White
- Material : Aluminum
- Product dimensions / weight : 310x260x49mm(12.21x10.24x1.93") / 3,200g (7.06lb)
- Max. load : 40kg

Compatible Devices



SBP-150NBW

SBP-150PMW

Pole Mount



Specifications

Mechanical	
Color	White
Material	Aluminum
RAL code	RAL9003
Product dimensions / weight	310x260x49mm(12.21x10.24x1.93") / 3,200g(7.06lb)
Tile thickness	※ Pole thickness ø80~200mm(ø3.15~7.88"): Using vice grip ø200mm~(ø7.88"~): Using steel strap
Mount Screw size	TR30, M12
Max. load	40kg
Conduit hole	19.1mm(3/4")(M25)
Supported products	SBP-150NBW, TNO-A26081 ※ For further compatible models, please visit our website or use Toolbox

SBP-150PMW

Pole Mount



CAD

Unit: mm [inch]

SBP-150PMW Pole Mount

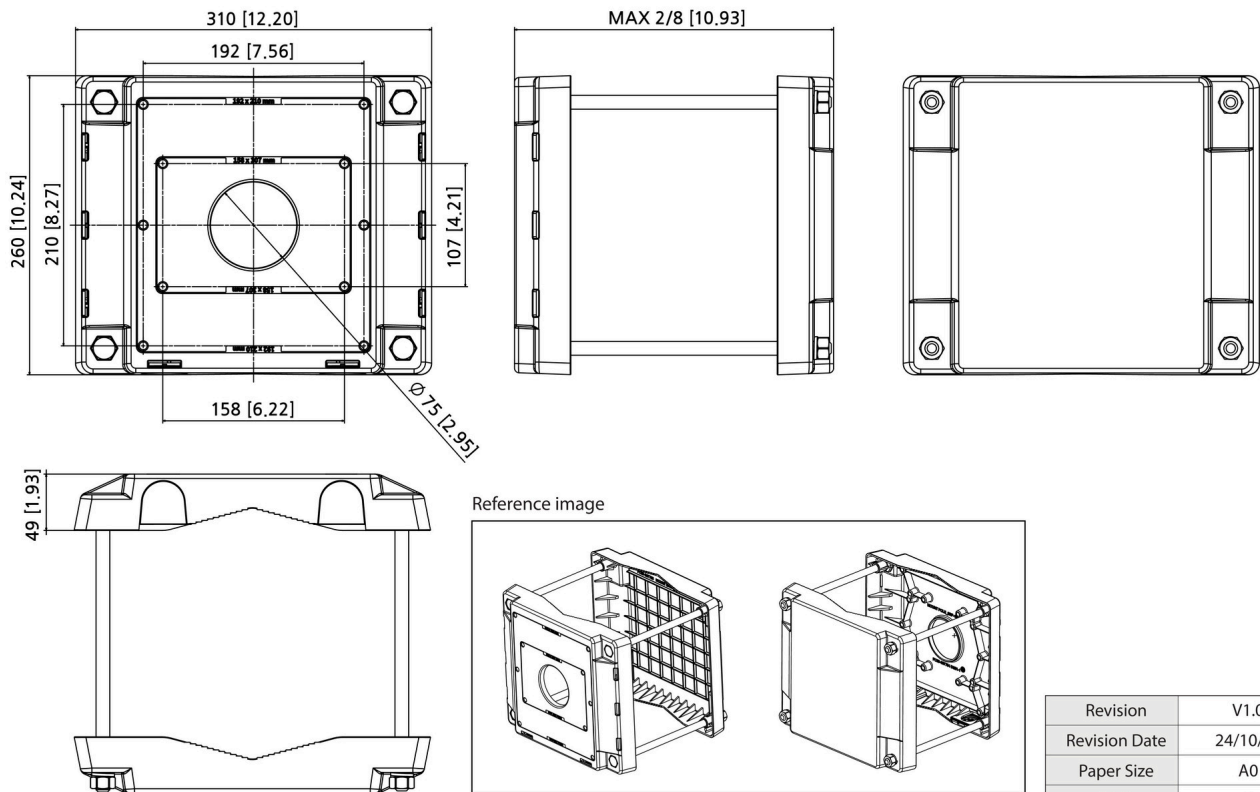

© Hanwha Vision Co., Ltd. All right reserved.

Revision	V1.0
Revision Date	24/10/17
Paper Size	A0
Unit	mm [inch]
Scale	1 : 1