

# 5MP LightHunter Active Deterrence Mini PTZ Camera IPC6325LFW-AX5C-VG



## Features

- High quality image with 5 MP, 1/2.8" CMOS sensor
- Ultra 265, H.265, H.264, MJPEG
- Smart intrusion prevention, supports false alarm filtering, including cross line, intrusion, enter area, leave area detection
- LightHunter technology ensures ultra-high image quality in low illumination environment
- Up to 120 dB WDR (wide dynamic range)
- Built-in mic and speaker
- Smart IR, up to 50 m (164.0 ft) IR distance and 15 m (49.2 ft) warm light distance
- MicroSD, up to 512 GB
- IP66 protection
- DC 12 V, PoE (IEEE 802.3at) power supply

## Specifications

| Model                      | IPC6325LFW-AX5C-VG   |
|----------------------------|--|
| <b>Camera</b>              |  |
| Max Resolution             | 5 MP   |
| Sensor                     | 1/2.7" CMOS  |
| Min. Illumination          | Color: 0.005 Lux (F1.2, AGC ON), 0 Lux with IR   |
| Day/Night                  | IR-cut filter with auto switch (ICR)   |
| Shutter                    | Auto/Manual, 1 to 1/100000 s   |
| WDR                        | 120 dB   |
| S/N                        | >56 dB   |
| <b>Lens</b>                |  |
| Focal Length               | 2.7 to 13.5 mm   |
| Optical Zoom               | 5X   |
| Iris                       | F1.2   |
| Field of View (H)          | 106.9° to 30.6°  |
| Field of View (V)          | 56° to 17.7°   |
| Field of View (D)          | 131.5° to 36.1°  |
| <b>DORI</b>                |  |
| DORI Distance (Detect)     | 70.9 m to 247.5 m (232.5 ft. to 812.0 ft.)   |
| DORI Distance (Observe)    | 28.4 m to 99.0 m (93.2 ft. to 324.8 ft.)   |
| DORI Distance (Recognize)  | 14.2 m to 49.5 m (46.5 ft. to 162.4 ft.)   |
| DORI Distance (Identify)   | 7.1 m to 24.8 m (23.3 ft. to 81.4 ft.)   |
| <b>Video</b>               |  |
| Privacy Mask               | Up to 4 areas  |
| Video Compression          | Ultra 265, H.265, H.264, MJPEG   |
| Frame Rate                 | Main Stream: 5 MP (2880 × 1620), max. 30 fps<br>Sub Stream: 720P (1280 × 720), max. 30 fps<br>Third Stream: D1 (720 × 576), max. 30 fps  |
| Video Bit Rate             | 128 Kbps to 16 Mbps  |
| U-code                     | Support  |
| ROI                        | Support  |
| Video Stream               | Triple streams   |
| OSD                        | Up to 8 OSDs   |
| <b>Intelligent</b>         |  |
| Auto Tracking              | Support, target filtering: human only  |
| Smart Intrusion Prevention | Cross line detection, intrusion detection, enter area detection, leave area detection (support false alarm filtering and the classification of human, non-motor vehicle and vehicle) |
| People Counting            | Support people flow counting and crowd density monitoring  |
| Exception Detection        | Object removed, Object Left Behind, Scene change, Defocus detection  |
| <b>Image</b>               |  |
| White Balance              | Auto, Outdoor, Fine tune, Sodium lamp, Locked, Auto2   |
| Digital Noise Reduction    | 2D/3D DNR  |

|                                    |  |
|------------------------------------|--|
| Flip                               | Normal, Flip vertical, Flip horizontal, 180°   |
| HLC                                | Support  |
| BLC                                | Support  |
| Smart IR                           | Support  |
| Defog                              | Digital defog  |
| <b>Illuminator</b>                 |  |
| Light On/Off Control               | Auto/Manual  |
| Wavelength                         | 850 nm   |
| Illumination Distance (IR)         | 50 m (164.0 ft.)   |
| Illumination Distance (Warm Light) | 15 m (49.2 ft.)  |
| <b>Events</b>                      |  |
| Basic Detection                    | Motion detection, Tampering alarm, Audio detection, Object removed, Object Left Behind, Scene change, Defocus detection  |
| General Function                   | Watermark, IP address filtering, Access policy, ARP protection, RTSP authentication, User authentication   |
| <b>Audio</b>                       |  |
| Audio Compression                  | G.711U, G.711A   |
| Audio Bitrate                      | 128 Kbps   |
| Two-way Audio                      | Support  |
| Suppression                        | Support  |
| Sampling Rate                      | 16KHZ  |
| <b>Storage</b>                     |  |
| Edge Storage                       | MicroSD, up to 512 GB  |
| Network Storage                    | ANR, NAS (NFS)   |
| <b>Network</b>                     |  |
| Protocols                          | TLS1.3, SSH, IGMP, RTP, RTCP, SMTP, IPv4, IPv6, ICMP, ARP, TCP, UDP, DHCP, PPPoE, RTSP, RTMP, DNS, DDNS, NTP, FTP, UPnP, HTTP, HTTPS, 802.1x, SNMP, QoS, SSL/TLS   |
| Compatible Integration             | ONVIF (Profile S, Profile G, Profile T, Profile M), API, SDK   |
| Security                           | Password Protection, Strong Password, HTTPS Encryption, Export Operation Logs, Basic and Digest Authentication for RTSP, Digest Authentication for HTTP, TLS 1.2, WSSE and Digest Authentication for ONVIF |
| Client                             | EZStation, UNV-Link, UNV-Link Pro  |
| Web Browser                        | Plug-in required live view: IE 10 and above, Chrome 45 and above, Firefox 52 and above, Edge 79 and above  |
| <b>PTZ</b>                         |  |
| Number of Presets                  | 1024   |
| Preset Patrol                      | 16 patrols, up to 64 presets for each patrol   |
| Patrol Stay Time                   | 120 s to 1800 s  |
| Home Position                      | Support  |
| Pan Range                          | 0° to 345°   |
| Tilt Range                         | -10° to 100°   |
| Pan Speed                          | 1°/s to 50°/s  |

|                      |   |
|----------------------|---|
| Tilt Speed           | 1°/s to 40°/s   |
| <b>Interface</b>     |   |
| Audio I/O            | 1 Input: impedance 1 kΩ, amplitude 2.5 V [p-p], 1 Output: impedance 600 Ω, amplitude 2.5 V [p-p]  |
| Alarm I/O            | 1/1   |
| Built-in Mic         | Support   |
| Built-in Speaker     | Support   |
| Network              | 1 × RJ45 10 M/100 M Base-TX Ethernet  |
| <b>Certification</b> |   |
| EMC                  | CE-EMC (EN 55032: 2015+A11: 2020+A1: 2020, EN 50130-4: 2011+A1: 2014, EN 61000-3-3: 2013+A1: 2019+A2: 2021, EN IEC 61000-3-2: 2019+A1: 2021)  |
| Safety               | CE LVD (EN 62368-1: 2020+A11: 2020)<br>UL (UL 62368-1, 2nd Ed., Issue Date: 2014-12-01)   |
| Environment          | CE-ROHS (2011/65/EU;(EU)2015/863)   |
| Protection           | IP66 (IEC 60529:1989+AMD1:1999+AMD2:2013)   |
| <b>General</b>       |   |
| Power                | DC 12 V (±25%), PoE (IEEE 802.3at)  |
| Power Consumption    | 18 W  |
| Power Interface      | Ø5.5 mm coaxial power plug  |
| Dimensions           | 185 mm × 133 mm × 286 mm (7.3" × 5.2" × 11.3") (L × W × H)  |
| Weight               | 1.32 kg (2.91 lb.)  |
| Working Environment  | -30°C ~ 60°C (-22°F ~ 140°F), Humidity: ≤95% RH (non-condensing)  |
| Storage Environment  | -40°C ~ 70°C (-40°F ~ 158°F), Humidity: ≤95% RH (non-condensing)  |
| Surge Protection     | 2 KV  |
| Reset Button         | Support   |
| Heater               | Support   |
| Web Client Language  | 22 Languages: Traditional Chinese, English, Simplified Chinese, Polish, German, Russian, French, Korean, Dutch, Czech, Portuguese (Europe), Portuguese (Brazil), Japanese, Thai, Turkish, Spanish (Latin America), Spanish (Europe), Hungarian, Italian, Vietnamese, Arabic, Slovak |
| <b>Configurable</b>  |   |
| P/N                  | Support   |

## Dimensions

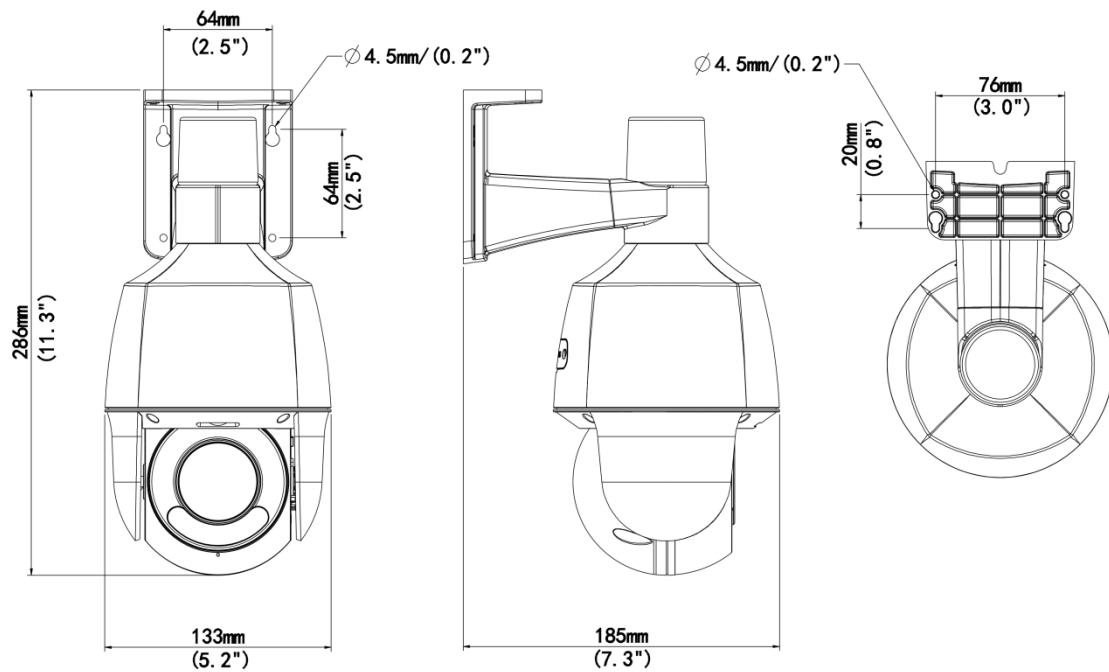

## Accessories

### TR-JB07-D-IN

Bullet Junction Box(Support wiring from behind)



### TR-UP06-C-IN

Pole Mounting Bracket for Bullet Junction Box Only



### TR-CM06-D

Alarm Ball Machine Hoisting Bracket



### TR-UP06-B-IN

Bullet Pole Mounting Bracket



### TR-A01-IN

NPT 3/4" Waterproof Cable Gland



# Unlimited New View

## Zhejiang Uniview Technologies Co., Ltd.



<http://www.uniview.com>



[overseasbusiness@uniview.com](mailto:overseasbusiness@uniview.com); [globalsupport@uniview.com](mailto:globalsupport@uniview.com)



No. 369, Xietong Road, Xixing Sub-district, Binjiang District, Hangzhou City, 310051, Zhejiang Province, China  
(Zhejiang) Pilot Free Trade Zone, China



©2023-2025 Zhejiang Uniview Technologies Co., Ltd. All rights reserved.

\*Product specifications and availability are subject to change without notice.

\*Despite our best efforts, technical or typographical errors may exist in this document.

Uniview cannot be held responsible for any such errors and reserves the right to change the contents of this document without prior notice.