



P17BH-AB-400G

Gvision's P17BH is a 17" industrial grade commercial monitor designed for use in the professional industry. It's the perfect solution for harsh environment.

DIMENSIONS

Unit: Inch

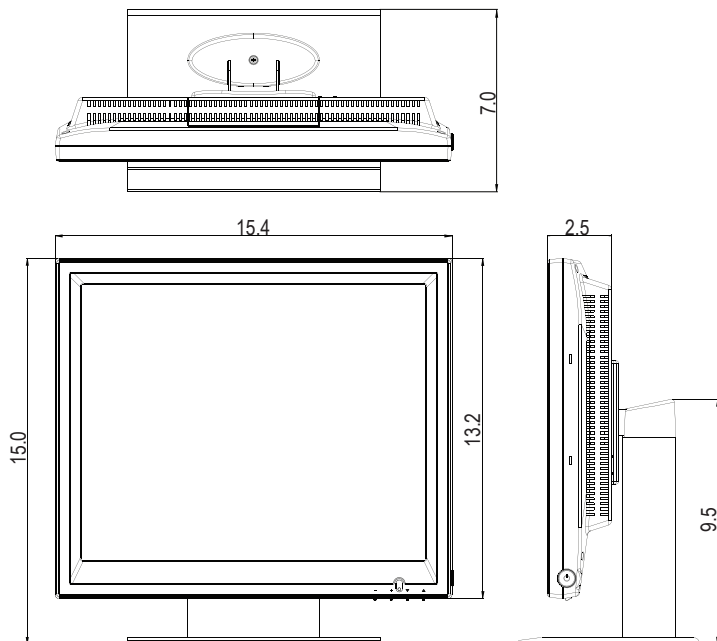

FEATURES

- 17-Inch Screen Size
- SXGA 1280 x 1024 Resolution
- Supporting Inputs: DVI-D / VGA / Audio
- 350 nits High Brightness
- LED Direct Backlight Unit
- Integrated Stereo Speakers
- Designed for 24/7 Operation
- 3-Year Warranty

SPECIFICATIONS

DISPLAY	P17BH-AB-400G
Screen Size	17 In
Resolution	1280 x 1024
Backlight	LED
Aspect Ratio	5 : 4
Viewing Angle	170° / 160°
Brightness	350cd/m ²
Contrast Ratio	1000 : 1
Color Depth	16.2 M
Response Time	5ms
Display Area (H x V)	337.9 (H) x 270.3 (V) mm
INTERFACE	
DVI	1
VGA (15 Pin D-Sub)	1
Audio	1
AUDIO	
Speaker	2 (1W/channel)
CABINET	
Material	Plastic
Color	Black
POWER	
Consumption	TBD
Electrical Ratings	AC 100V ~ 240V, 50/60Hz
TEMPERATURE	
Operating	32° F ~ 104° F (0° C ~ 40° C)
Storage	-4° F ~ 140° F (-20° C ~ 60° C)
Humidity	10% ~ 90%
DIMENSIONS (WxHxD)	
Inch (in)	15.4 x 15.0 x 7.0
Millimeter (mm)	392.3 x 381.5 x 180.2
WEIGHT	
Net Weight	14.1 lbs (6.4 kg)
CERTIFICATION	
Certificate	FCC / UL / cUL
VESA™	
Mount Size (mm)	100 x 100

Specifications subject to change without any notice