



19 Inch / Projected Capacitive PCAP Touch Monitor

D19ZH-AV-K5P0

DESKTOP TOUCH



Gvision manufactures a variety of desktop and point of sale (POS) monitors. This 19" touch screen monitors are available with 10-point multi touch projected capacitive (PCAP) screens. D19ZH support HDMI, DVI-D and VGA input interface to display superior quality images.



10-Points Touch



DVI-D Digital Input



HDMI Digital Input



VGA Analog Input



USB B-Type Touch

LED

Backlight Unit



3-Year Warranty

19-Inch 10-Points PCAP Touch Screen Monitor



INPUT INTERFACE



GVision's Desktop / POS monitor supports both digital and analog inputs to use as normal office desktop monitor with DVI, VGA, HDMI input or USB-Type B to use touch function as well.

DIMENSION

Unit: Inch

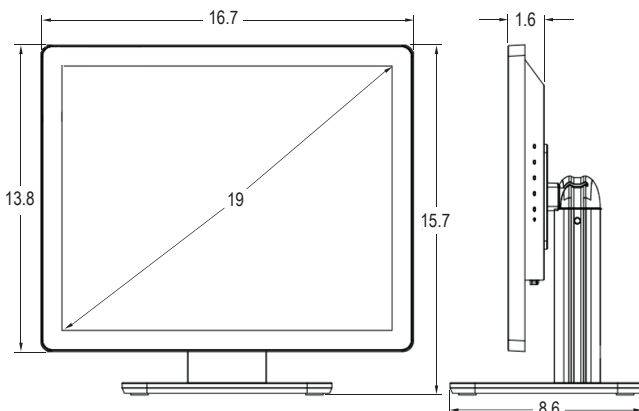

FEATURES

- 19-Inch Screen Size
- 1280 x 1024 Resolution
- Video Signal: **HDMI / DVI / VGA** (15 Pin D-Sub)
- **10-Points** Projective Capacitive **PCAP** Touch Technology
- **IP65** on the Front (Touch Screen with Frame)
- **Zero Pressure** Touch Activation
- **LED** Backlight Unit
- **Metal** Enclosure Material
- **3-Year** Warranty

SPECIFICATIONS

DISPLAY	D19ZH-AV-K5P0
Screen Size	19 In
Resolution	1280 x 1024
Backlight	LED
Aspect Ratio	5 : 4
Viewing Angle	170° / 160°
Response Time	5ms
Brightness	250cd/m ²
Contrast Ratio	1000 : 1
Color Depth	16.7 M
Display Area (mm)	376.32 x 301.06mm
INTERFACE	
HDMI	1
DVI	1
VGA (15 Pin D-Sub)	1
Audio	1
USB (B-Type)	1
TOUCH TECHNOLOGY	
Material	2 mm Glass
Points / Type	10 Max / Projected Capacitive (PCAP)
Accuracy	2 mm
CABINET	
Material	Plastic Frame / Metal Housing
Color	Silver Frame / Black Housing
POWER	
Consumption	20W Max Standby ≤ 0.5W
Electrical Ratings	12VDC ± 5% (Adapter Input AC 100V ~ 240V, 50/60Hz)
TEMPERATURE	
Operating	32° F ~ 104° F (0° C ~ 40° C)
Storage	-4° F ~ 140° F (-20° C ~ 60° C)
HUMIDITY	
Operating	20% ~ 80%
Storage	10% ~ 90%
DIMENSIONS (WxHxD)	
Inch (in)	16.7 x 14.7 x 8.6
Millimeter (mm)	425.9 x 399.2 x 220.0
WEIGHT	
Net Weight	15.8 lbs (7.2 kg)
COMPLIANT	
Certification	CE / FCC
VESA™	
Mount Size (mm)	100 x 100

Specifications subject to change without any notice