

TAA 
COMPLIANT

17-Inch / Projective Capacitive PCAP Touch Monitor

D17ZH-AV-45PT

DESKTOP TOUCH

Gvision's D17ZH-AV-45PT is a TAA compliant product with 10-Point Projected Capacitive PCAP touch and 5:4 aspect ratio. It is compatible with Windows® and Linux operating system, making it suitable for many environments.



- 
 1280x1024 Resolution
- 
 10-Point PCAP Touch
- 
 DVI-D Digital Input
- 
 HDMI Digital Input
- 
 VGA Analog Input
- 
 USB B-Type Touch
- 
 TAA Compliant
- 
 IP65 Protected
- 
 Built-In Speaker
- 
 LED Backlight Unit
- 
 3-Year Warranty

17-Inch / 10-Point PCAP Touchscreen / TAA Compliant



FEATURES

- 17-Inch Screen Size / 1280 x 1024 Resolution
- Interface: HDMI / DVI / VGA (15 Pin D-Sub)
- IP65 on the Front (Option)
- Zero Bezel Touch Screen
- 1W Two Built-In Speakers
- LED Backlight Unit
- Metal Enclosure Material
- 90 Degree Tilt Stand
- TAA Compliant
- 3-Year Warranty

INPUT INTERFACE



Gvision's Desktop Monitor supports both digital and analog inputs with VGA, DVI & HDMI inputs. Touch is activated when the provided USB cable is connected.

DIMENSIONS

Unit: Inch

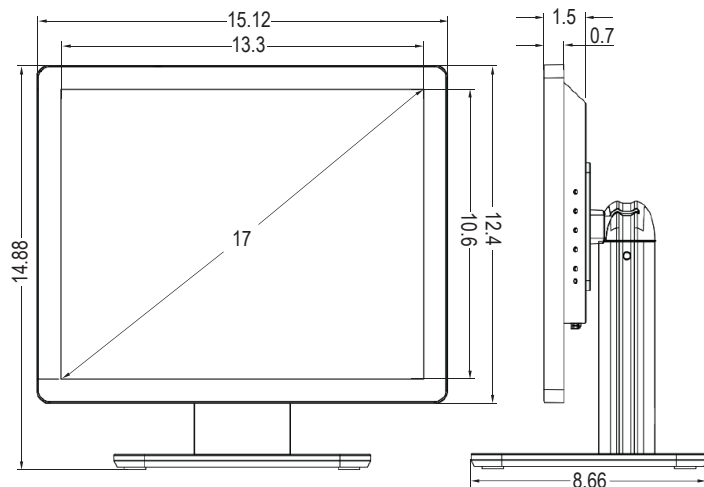

SPECIFICATIONS

DISPLAY		D17ZH-AV-45PT
Screen Size		17 In
Resolution		1280 x 1024
Backlight		LED
Aspect Ratio		5 : 4
Viewing Angle		170° / 160°
Response Time		5ms
Brightness		250cd/m ²
Contrast Ratio		1000 : 1
Color Depth		16.7 M
Display Area (mm)		337.9 x 270.3mm
INTERFACE		
DVI		1
HDMI		1
VGA (15 Pin D-Sub)		1
Audio		1
TOUCH TECHNOLOGY		
Glass		2mm Tempered Glass
Type		10-Point Projected Capacitive Touch (PCAP)
Support OS		Windows® / Linux
AUDIO		
Speakers		1W x 2
CABINET		
Material		Metal
Black		Black
POWER		
Consumption		< 18W
Electrical Ratings		12V DC ± 5% (AC 100V ~ 240V, 50/60Hz)
TEMPERATURE		
Operating		32° F ~ 104° F (0° C ~ 40° C)
DIMENSIONS (WxHxD)		
Inch (in) w/o Stand		15.12 x 14.88 x 8.66
Millimeter (mm) w/o Stand		384.2 x 378.0 x 220.0
WEIGHT		
Net Weight (w/ Stand)		13.6 lbs (6.2kg)
COMPLIANT		
Certification		TAA / CE / FCC
VESA™		
Mount Size (mm)		100 x 100

Specifications subject to change without any notice